

Culligan

Aqua-Cleer

MFP/3 ^{CE}

EQUIPMENT FOR DRINKING AND TECHNOLOGICAL WATER

Technical information



GENERAL

The capability for purifying water chemically and bacteriologically in a single operation is the unique feature of Reverse Osmosis, which allows a salt removal of 90%-95% (depending on the nature of the salts concerned). What's more, the osmotic membranes reject bacteria, viruses and pyrogens, preventing them from passing into the purified water produced.

This continuous, physical process does not involve the use of regenerating agents. Electricity consumption is low. The operation of Reverse Osmosis systems does not require specialist staff, and nor are complicated control systems necessary.

Culligan Reverse Osmosis devices are the best, most modern systems on the market today.

They can easily be inserted in a complete pre- and post-treatment system for the most demanding uses.

CONSTRUCTION FEATURES

Culligan Aqua-Cleer MFP/3 Series models are designed and built to the highest quality, safety and noise reduction standards.

The construction materials used, especially those of the parts in contact with the water, all have proven resistance to corrosion and do not trigger shedding phenomena.

CONTROL AND MONITORING - All the electrical components, contained in an airtight protective casing (IP 55), meet the most widely adopted European Standards. The three-phase motor (IP 44 class F), of rugged construction, is compliant with current safety requirements.

Some lighten keys on the control board show continuously the current operation step.

FLEXIBILITY - Operation of all Culligan Aqua-Cleer MFP/3 Series models is extremely flexible. With nominal temperature of 20°C, at system start-up the recovery ratio between product water and raw intake water may be set from 40% to 75% depending on the data of the technical specifications shown in the table. The same recovery ratios may also be retained at different temperatures.

FLUSHING AND DISINFECTION - All Culligan Aqua-Cleer MFP/3 Series models are designed for easy connection to an external system for flushing and automatic disinfection of the osmotic modules.

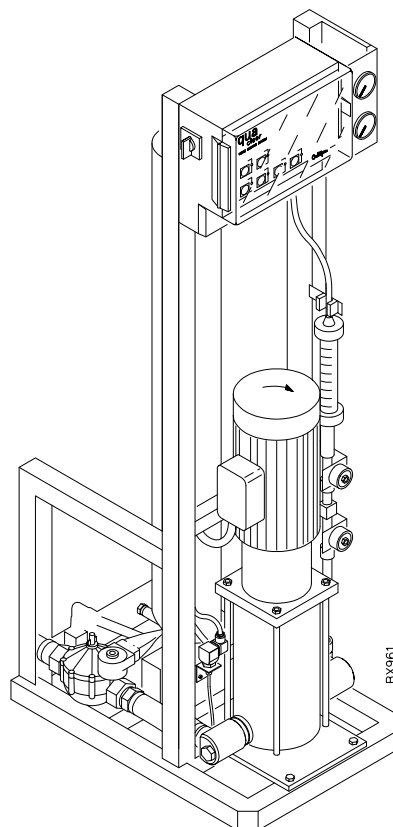

M002-44 - Rev. 01 - 11/2007

Quality System Certified according to UNI EN ISO 9001:2000 Norm

CULLIGAN ITALIANA S.p.A. - Via Gandolfi, 6 - 40057 Cadriano BO (ITALY) - Phone +39/0516017111 - fax +39/051765602

INTAKE WATER CHARACTERISTICS

Hydraulic pressure : - > 0.5 bar for operation only
 - ≥ 2 bar to guarantee rated performance
 - > of the pressure required at the user in case of pressurised distribution of product

Product pressure : 3 bar max

Temperature : 2-35°C (nominal temperature 20°C)

Maximum salinity
 mod. from 400 to 1600 : 3000 mg/l (as TDS)
 mod. from 2200 to 3300 : 1500 mg/l (as TDS)

SDI : ≤ 3

pH : 7 ± 1

Activated chlorine : absent (or ≤ 0.1 ppm)

Calcium Sulphate : concentration in reject water below solubility limit

Calcium Carbonate : Negative Langelier Index in reject water

Silica : concentration in reject water below solubility limit.

N.B.: if necessary, the turbidity values required can be achieved with suitable prefiltration.

PRODUCT CORRECTION FACTOR IN RELATION TO TEMPERATURE

Intake water temperature	Correction factor for the temperature considered
10°C	0.63
11°C	0.67
12°C	0.71
13°C	0.74
14°C	0.77
15°C	0.81
16°C	0.86
17°C	0.89
18°C	0.93
19°C	0.96
20°C	1*
21°C	1.04
22°C	1.07
23°C	1.11
24°C	1.14
25°C	1.18
26°C	1.23
27°C	1.26
28°C	1.31
29°C	1.36
30°C	1.40

* Nominal capacity at 20°C

N.B.: with temperatures lower or higher than the limits set (2-35°C) there may be irreversible physical damage to the membranes (due to frost or the deterioration of the osmotic film).

TECHNICAL SPECIFICATIONS

Model MFP/3	Nominal Flow-Rates and Pressures		Osmotic Modules		Recovery Ratio	Connections		Motor Power	Dimensions			Ship-ment Weight (-) kg
	Product (1) l/h	Intake bar	Q.ty	Mod.		Water Female IN – OUT	Electrical 3-ph + earth + neutral		Width mm	Depth mm	Height mm	
400	500	13	1	4641 HF	40-75%	1" - 3/4"	3x380V 50Hz	1.5	500	660	1550	115
800	1000	13	2	4641 HF	40-75%	1" - 3/4"	3x380V 50Hz	1.5	500	660	1550	140
1200	1500	13	3	4641 HF	50-75%	1" - 3/4"	3x380V 50Hz	2.2	500	660	1550	170
1600	2000	13	4	4641 HF	60-75%	1" - 3/4"	3x380V 50Hz	2.2	500	660	1550	190
2200	2500	18	4	4641 HF	50-75%	1" - 3/4"	3x380V 50Hz	4	500	660	1800	220
2800	3000	18	5	4641 HF	60-75%	1" - 3/4"	3x380V 50Hz	4	500	660	1800	250
3300	3500	18	6	4641 HF	70-75%	1" - 3/4"	3x380V 50Hz	4	500	660	1800	280

1) Mean values calculated in the following conditions: water temperature 20°C; operating pressure 13 or 18 bar; recovery percentage 75%; raw H₂O salinity 500 ppm NaCl; product H₂O pressure 0 bar; new modules.

N.B.: minimum water intake pressure: 2 bar

CAUTION: even in more favourable conditions (e.g. high temperature), in order to ensure correct operation of the system the nominal flow-rates must never be exceeded. If necessary, reduce the intake pressure.

M002-44 – Rev. 01 - 11/2007